

**UNITED REPUBLIC OF TANZANIA  
MINISTRY OF FINANCE AND ECONOMIC AFFAIRS**



**MILLENNIUM CHALLENGE ACCOUNT – TANZANIA**

**ELECTRICITY LOSS REDUCTION STUDY**



**Final Report  
EXECUTIVE SUMMARY  
JUNE 2011**



**AZOROM** 



## Table of Contents

<b>1</b>	<b>Introduction</b>	<b>4</b>
1.1	Objectives of the Project	4
1.2	Work Plan	4
1.3	Training Programme	4
<b>2</b>	<b>Scope and Methodology</b>	<b>5</b>
<b>3</b>	<b>Total Systems Losses</b>	<b>5</b>
3.1	TANESCO System Losses	5
3.2	TANESCO Estimated Loss costs	7
3.3	ZECO System Losses	8
3.4	ZECO Estimated Loss costs	9
3.5	International Benchmarking	10
<b>4</b>	<b>Technical Losses Reduction</b>	<b>10</b>
4.1	Technical Losses Reduction Strategies	10
4.1.1	Policy	10
4.1.2	Reduction Strategies	11
4.1.3	Loss management	11
4.2	Technical loss Reduction Programme	12
4.2.1	Specific Remedial measures	12
4.2.2	Capacitors	12
4.2.3	11 to 33kV Voltage Conversion	12
4.2.4	New MV/LV Transformers	13
4.2.5	REconductoring LV Networks	13
4.2.6	Summary	13
4.3	Three & Five Year Plans	14
4.3.1	TANESCO Three-Year Programme	14
4.3.2	ZECO Three-Year Programme	16
<b>5</b>	<b>Commercial Losses Reduction</b>	<b>17</b>
5.1	Commercial Loss Reduction Strategies	17
5.1.1	Surveys	17
5.1.2	Revenue protection Strategy	18
5.2	Three & five Year Plans	20
5.2.1	Three-Year Plan 2011-20-13	20
5.2.2	Five-Year Plan 2014-20-15	22
5.3	Economic Analysis of the Programme	22
<b>6</b>	<b>Conclusions and Recommendations</b>	<b>24</b>
6.1	Conclusions in Summary	24
6.2	Main Recommendations	24
 <b>Appendices</b>		
<b>A</b>	Allocation of electricity costs – TANESCO	
<b>B</b>	Energy Flows 2010 – TANESCO	
<b>C</b>	Energy Flows 2009 – ZECO	

## Main Abbreviations

CAS:	Customer Accounting System
EWURA:	Energy and Water Utilities Regulatory Authority
KPI	Key Performance Indicator
MCA-T:	Millennium Challenge Account - Tanzania
PSMP:	Power System Master Plan
RP:	Revenue Protection
SNCL:	SNC Lavalin (Tariffs Study on ZECO 2009)
T & D:	Transmission and Distribution
TANESCO:	Tanzanian Electric Supply Company Ltd.
ZECO:	Zanzibar Electricity Corporation
USO:	Units Sent Out

## Some Definitions

**Technical Losses:** *Energy that is produced but not delivered to Customers*

**Non-Technical Losses = Commercial Losses:** *Energy that is delivered to Customers but not billed*

**Revenue Losses:** *Energy that is billed but not paid for.*

**Vishoka** (lit: *small axe choppers*). People who, for reward, encourage energy consumers to defraud utilities through meter tampering or illegal connections.

## Acknowledgements

AZOROM - AETS wish to thank the many people they met in MCA-T, TANESCO, ZECO and EWURA and who supported them during the Study. In particular, our thanks go to: Isaac Chanji; Peter Kigadye and Florence Gwan'gombe of MCA-T; to the MCC Project Co-ordinators Boniface Njombe and Thabit Khamis; to the Co-ordinators allocated to us in TANESCO (Simon Kihyo and Benedict Bahati) and ZECO (Mussa Ali Mussa; Faki Hamad Ali and Said Hamad Bakar). A special thank you to the support staff in MCC offices, Ubungu, Dar es Salaam who looked after us: Ahsanteni sana!

# 1. Introduction

A contract between Millennium Challenge Account – Tanzania and AZOROM Ltd (Ireland), in association with AETS (France), for a technical and commercial loss-reduction study was signed on the 9<sup>th</sup> November 2010. The Final Report is due for approval by June 28<sup>th</sup> 2011.

## 1.1 Objectives of the Project

The three objectives as outlined in the Project RFP are:

- Reduce the current total level of technical and non-technical losses to 18% by 2013 in TANESCO from an estimated 24% and to 20% by 2013 in ZECO from an estimated 27.5%
- Establish the level of system losses for both TANESCO and ZECO and accurately allocate these losses into technical and non-technical, and also identify the main sources and causes of these losses.
- Derive the value of system capacity (MW) and energy (MWh) for both entities and identify the cost benefit of reducing losses.

## 1.2 Work Plan

The Study involved a 6 month schedule of consultancy work in collaboration with both utilities, along with a further month for final reports. The work plan involved 6 main areas of activity:

- Inception Phase: from a “kick-off” meeting on November 29th through December 2010
- Data Gathering and Analysis Phase, including numerous meetings with HQ and Regional managers and staff
- Field Surveys of networks and customer installations
- Load flows and losses analysis
- Development of recommendations, with economic and financial analysis, for managing reduction of losses
- Training programme (Workshops and Presentations)

## 1.3 Training Programmes

Training was a crucial element of the work plan and was carried out comprehensively over the April/May 2011 period. A detailed programme was developed and circulated for agreement on March 31<sup>st</sup>, and the first component, an intensive 2-day course on field surveys and inspections and loss calculations, was held for engineers and technicians from both utilities on April 26/27<sup>th</sup>.

Six further one-day workshops were held for managers and staff involved with Technical and Commercial losses during May. Finally, a series of Presentations on the conclusions and

recommendations of the draft Final Report was given to Senior Managers from both utilities on May 24<sup>th</sup>.

## 2 Scope and Methodology

Load flow studies, using on-site measurements and suitable software tools, were carried out for sample networks in eight Regions in the TANESCO system, that is Dar-es-Salaam (4 Regions), Kilimanjaro, Arusha, Mwanza and Mbeya, and on the islands of Unguja and Pemba in the ZECO system.

- Analysis was carried out to evaluate the total level of losses on the TANESCO and ZECO systems. The total system loss levels are split between technical and non-technical losses and sources of both identified.
- An analysis of all Technical Losses on both systems was carried out using data from the field surveys and from utility metering. For MV and LV networks sample networks were selected randomly for data collection and load flow analysis. Loss performance for the sample networks could then be extrapolated to the whole system. From the load flow and loss calculations, it was possible to get a reasonably accurate estimate of losses at each voltage level on each system covering transformer and conductor losses
- Commercial Losses are the residual when Technical Losses are deducted from System Losses. Valuable data on the extent and sources of these losses was derived from Metering Inspections carried out by AZOROM surveyors on the sample networks
- Extensive discussions were held with managers and officials in HO departments and regions to establish current policies and approaches in managing commercial and technical losses
- The values of all losses above were computed for analysis. Costs of remedial measures to reduce these losses were also assessed. Then Cost Benefit Analysis was carried out on the programmes for loss reduction in order to rank them and establish the net present values of individual projects

## 3 Total System Losses

### 3.1 TANESCO System Losses

The “Sales Gap” is first determined in terms of the difference between the inputs to and outputs from the Transmission and Distribution (T&D) system. This information is illustrated in the diagram in Appendix B showing the energy flows through the various levels in the TANESCO system for 2010. Technical losses are illustrated by the arrows flowing to the right and down from the coloured boxes representing each of the system levels. This effectively is an energy audit for the system.

By performing load flow analysis on the individual levels in the T&D system, the technical loss rate for each such level is determined, in terms of the technical losses as a percentage of the input to that level. The loss rates derived are summarised in Figure 3.1.

<b>Network Loss Rates</b>		
Losses as % of Input to Level		
	kWh	kW
220kV Network + Stations	2.60	4.20
132 & 66kV Network	2.60	4.60
132 & 66kV Stations	0.80	1.20
33kV Network	2.40	3.30
33kV Stations	1.10	1.10
11kV Network	3.50	4.90
MV Subs	1.60	1.55
LV Network	5.25	8.20

**Figure 3.1 – TANESCO Technical Loss Rates - % Level Input**

Applying the loss rates to the through flows for each level in the system makes it possible to derive the technical losses at each level. These technical losses are aggregated for the system. The technical losses are subtracted from the sales gap, defined by the difference between units sent out and actual sales. This residue comprises commercial losses.

A separate analysis was performed for the condition of the system at peak time. This is significant because it determines the sizing or capacity (kVA) requirements in assigning costs to the various flows through the system. Applying these loss rates to the flows through the T&D system, the technical losses for each level in the system are calculated.

<b>Totals</b>	<b>GWH</b>	<b>% Units Total Sent Out</b>
Station Use	48.3	0.91
Sent Out to Trans	5,217.5	98.51
Distributed Gen	78.9	1.49
Trans. Loss	262.3	4.95
Dist. Loss	432.8	8.17
Comm. Loss	594.5	11.22
Sales	4,006.8	75.65

**Figure 3.2 – TANESCO System Energy Loss Performance – 2010**

The total system energy losses therefore come to a value of about 24.3% of inputs to the system. The breakdown of technical losses is shown in Figure 3.3

System Level	Losses
Transmission	5%
Distribution	8.1%
Total Technical	13.1%
Commercial	11.2%
Total	24.3%

Figure 3.3 TANESCO Losses Breakdown

### 3.2 TANESCO Estimated Loss Costs

The TANESCO technical losses are costed at US\$72 million in 2010. The allocation of losses and costs is illustrated in Figure 3.4

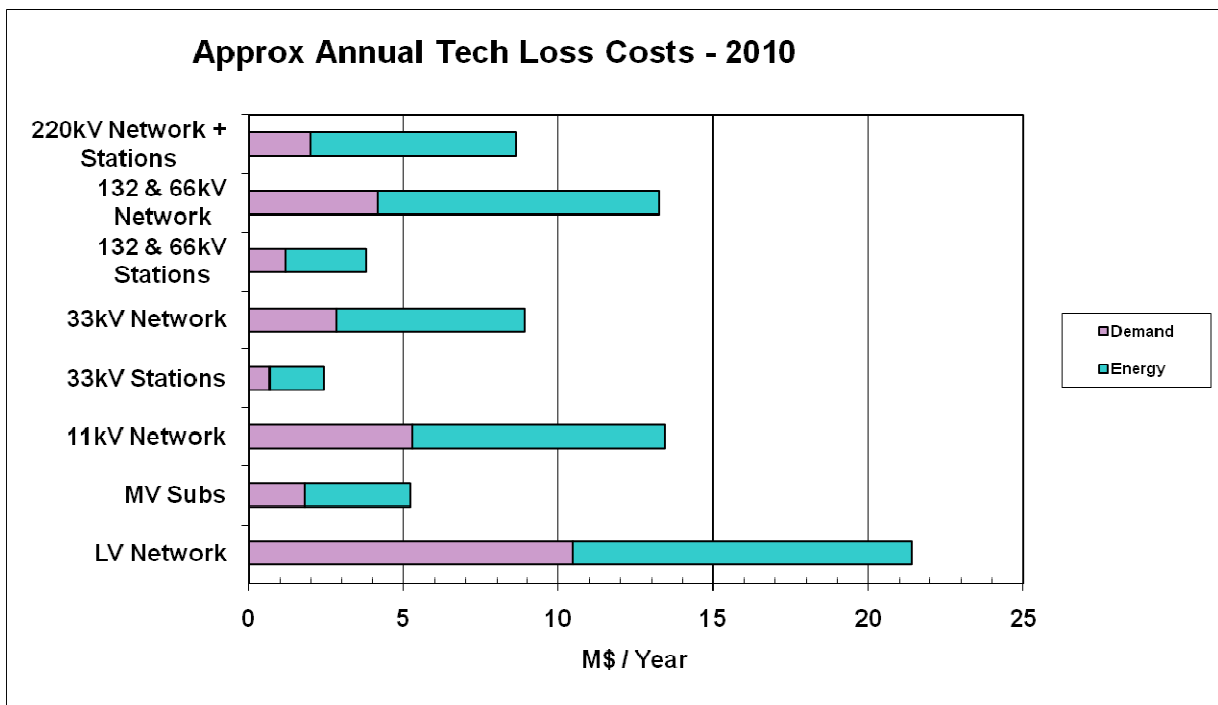
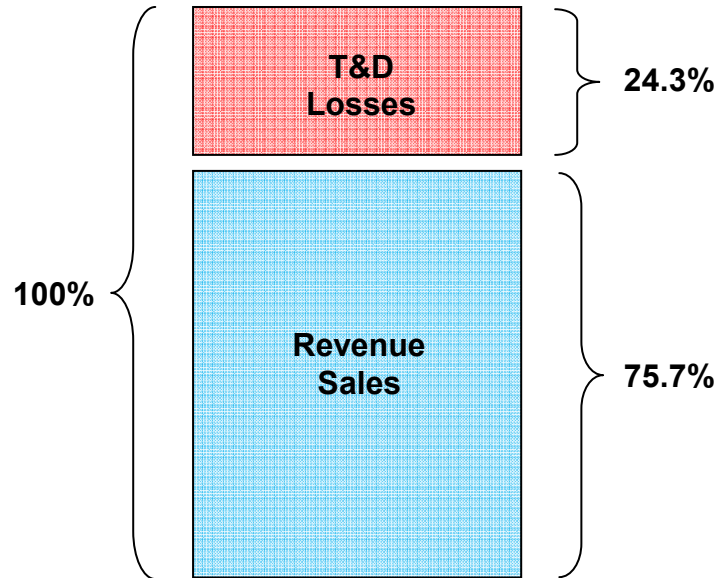

Figure 3.4 – TANESCO T&D Technical Loss Costs – 2010

The combined technical and commercial loss costs for distribution exceed the direct cost of distribution. Appendix A shows a 'pie' chart of estimated TANESCO costs and illustrates that the balance between the operating cost of losses and of capital expenditure in developing the distribution networks is badly out of alignment. Transmission losses are also an excessively high proportion of the total operating cost of the transmission system.



**Figure 3.5 – TANESCO Relative Loss Rates - 2010**

The overall T&D system loss rate for TANESCO including commercial losses was about 24.3% in 2010. Note that this is expressed as a percentage of inputs to the system.

The losses as a percentage of revenue sales are a considerably higher figure, i.e.  $24.3/75.7 = 32\%$ .

### 3.3 ZECO System Losses

The “Sales Gap” is first determined in terms of the difference between the inputs to and outputs from the T&D system. This information is assembled in the diagram in Appendix C. This diagram illustrates the energy flows through the various levels in the ZECO system for 2009. Note that analysis for ZECO is done for 2009 as 2010 data is still incomplete. By performing load flow analysis on the individual levels in the T&D system the technical loss rate for each such level can be determined i.e. in terms of the technical losses as a percentage of the input to that level. These are illustrated in Figure 3.6.

<b>Network Loss Rates</b>		
	Losses as % of Input to Level	
	kWh	kW
132kV Network	1.00	1.30
132kV Stations	1.00	1.05
33kV Network	2.00	2.80
33kV Stations	1.00	1.05
11kV Network	5.20	7.40
MV Subs	1.70	1.75
LV Network	5.80	9.20

**Figure 3.6 – ZECO Technical Loss Rates - % Level Input**

Figure 3.7 expresses the breakdown of the losses for ZECO in tabular form.

System Level	%Losses
Transmission	2%
Distribution	10.5%
Total Technical	12.5%
Commercial	13%
Total Losses	25.5%

**Figure 3.7 – ZECO Technical Loss Rates - % Level Input**

Note that the ZECO system losses at 25.5% are lower than the 27.5% estimated in the study terms of reference for 2008.

### 3.4 ZECO Estimated Loss Costs

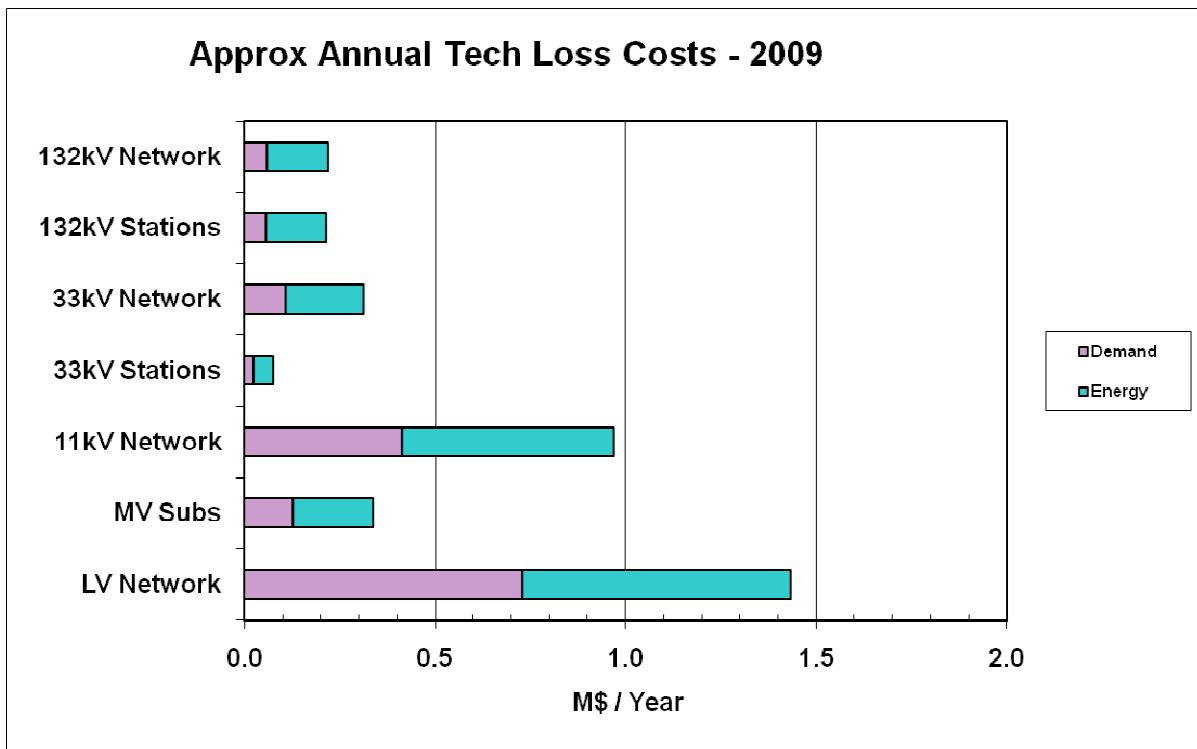

**Figure 3.8 – ZECO Technical Loss Costs – 2009**

The ZECO technical losses are costed at US\$3.6 million in 2009. The allocation of losses and costs is illustrated in Figure 3.8.

It also illustrates that the conductors contribute much more significantly to losses than the transformers. The network losses are higher at each voltage level than the associated

transformers. It is the network conductors, particularly the overhead lines, which require most attention in managing technical losses.

### 3.5 International Benchmarking

The chart in Figure 3.9 provides a breakdown of T&D losses for comparison with other countries. It can be seen that both TANESCO and ZECO loss levels are considerably higher than in a mature or optimal T&D system.

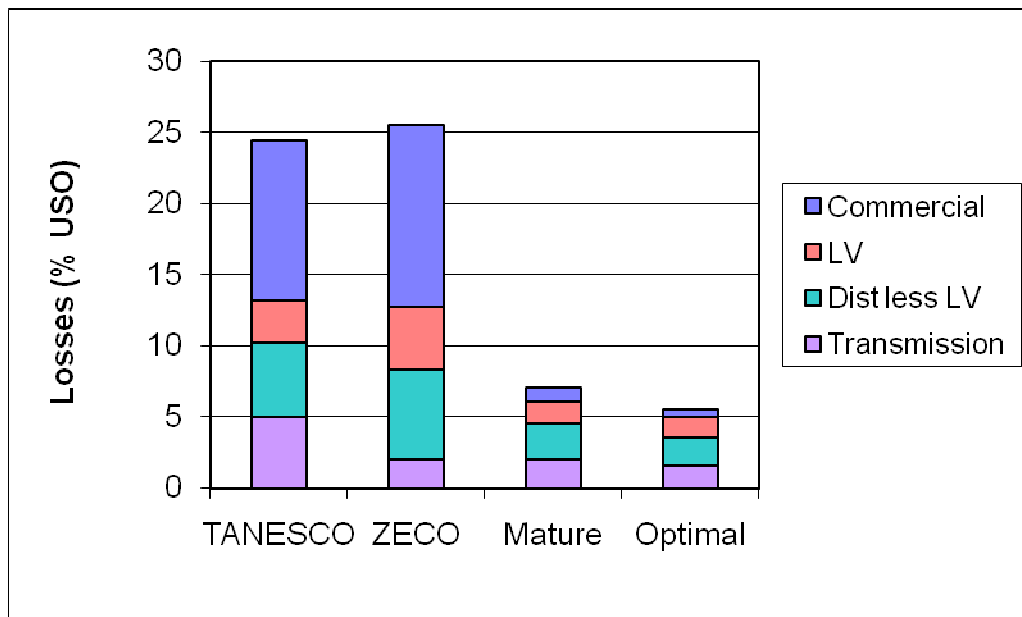

Figure 3.9 – Total T&D Loss Composition

## 4 Technical Losses Reduction

### 4.1 Technical Losses Reduction Strategies

#### 4.1.1 Policy

A corporate losses policy is needed to manage T&D losses effectively. This should be guided by the following principles:

- Technical losses are a major operating cost and need to be managed as such.
- They should be evaluated for all projects with costs, based on production and T&D capacity, included in project evaluations.
- Loss costs should be capitalised over the economic life of projects (typically 25 years for T&D assets) and at the currently approved corporate discount rate.

### 4.1.2 Reduction Strategies

Strategy for reducing technical losses is shaped by the following principles:

- The cheapest and most effective way to influence network performance is at the planning and design stage before networks are built. Network development is expensive and once built network assets are in place for many decades. Planning and design have to be right. Remedying deficiencies afterwards is very expensive.
- Loss efficiency needs to be fully incorporated in all transmission and distribution planning and project analysis. This builds loss efficiency into the networks over time in the most economical way.
- Technical loss reduction requires development on two fronts:
  - Optimise the normal planning and design processes for loss efficiency to ensure optimal network development and progressive improvement into the future. This is the medium and long term strategy.
  - The short term strategy is a specific program of loss reduction measures to alleviate the worst problems and achieve quick results.

### 4.1.3 Loss Management

In summary T&D loss management arises in the following areas:

- **Operational Loss Reduction:**
  - Sectionalise networks to distribute load as evenly as possible.
  - Balance load across phases, particularly on heavily loaded LV feeders.
- **Planning Loss Appraisal:**
  - Include loss analysis in all project appraisals to minimise total costs.
  - Consider implementation of a basic GIS application for the MV network
  - Utilise network planning software tools to improve the planning activity
- **Loss Reduction by Design:**
  - Capitalise losses at purchase to ensure energy efficient transformers.
  - Use economic conductor sizing.
  - Optimise MV / LV network design i.e. transformer size, number of feeders, conductor and service sizes etc.
- **Major Projects:**
  - LV Network Rehabilitation – New Subs & re-conductoring.
  - Capacitor Installation (mainly on 11kV lines)
  - 33 kV and 11 kV Network Development – voltage upgrades, new stations, re-conductoring

## 4.2 Technical Losses Reduction Programme

### 4.2.1 Specific Remedial Measures

The most efficient way to improve technical loss performance on both the transmission and distribution networks is to amend the processes for network development to build efficiency into the networks through normal network development. This takes time to produce results.

To achieve significant technical loss reduction in the short term additionally requires a specific program of remedial measures targeting the most problematic networks. These measures are summarised as follows:

- **11kV Networks:**
  - Power factor correction with capacitor installation.
  - 11to 33kV voltage conversion for heavily loaded 11kV lines.
  
- **LV Networks:**
  - New MV/LV transformers to relieve heavily loaded LV networks.
  - Reconductoring other heavily loaded LV feeders that do not qualify for a new transformer.

### 4.2.2 Capacitors

Capacitor installation to improve network power factors provides very cost effective loss reduction. The overall system impact is relatively small but the costs are very attractive, saving MVA capacity, reducing losses and improving voltage.

It is economical to correct power factors in excess of 0.95 up to about 0.98.

The proposed strategy is:

- To install fixed capacitors close to the middle of 11kV main feeders to fully compensate reactive power at minimum load.
- Within next 2 years target all 11kV lines with 2MVA or more of load and Power Factor of 0.88 or less
- In years 3 - 5 target 11kV lines with 2MVA or more of load and Power Factor of 0.90 or less
- To correct PF above 0.95 or towards 0.98 increasingly requires switched capacitors on 11kV busbars in HV/MV substations but these can still be economical.

### 4.2.3 11 to 33kV Voltage Conversion

Capacitor installation yields a modest improvement in 11kV network loss performance at low cost. However it does not address the more seriously over loaded networks. These require more significant development.

The options for relieving heavily loaded MV networks include:

- New HV/MV substation out in the network and re-sectionalising existing load onto the new substation.
- 11kV to 33kV voltage conversion.
- New 11kV feeder to relieve existing feeder or re-conductoring the heavier loaded sections of the feeder.

33kV voltage conversion yields more significant loss reduction benefit. Losses are reduced by some 90%. Conversion costs are also more predictable and will generally be lower than for the construction of a new substation. From a loss reduction perspective 33kV voltage conversion is a much more attractive option and is taken as the preferred major 11kV network development option.

#### **4.2.4 New MV/LV Transformers**

The major development option for overloaded LV networks is to install a new transformer out in the network near the centre of load congestion. Existing LV feeders are split and portions are connected to the new transformer to redistribute load between the available transformers. This provides significant LV load relief and approximately 75% loss reduction on the relieved feeder(s).

#### **4.2.5 Reconductoring LV Networks**

There are situations that do not justify such major development as a new transformer but can still benefit from a degree of re-conductoring. This is an additional development option. Approximately two thirds of the losses on a typical LV feeder with distributed load arises in the first one third of the main feeder length. Reconductoring this first third section can reduce the overall feeder losses by about a third. The ideal is to run a length of 4x95mm<sup>2</sup> bundle conductor on the existing poles and re-distribute some of the existing load onto this.

#### **4.2.6 Summary**

**In Summary:** All 4 Loss Remedies have been applied to TANESCO networks, based on the data gathered in the sample surveys and standard costs, with the outcome shown in Section 8: 3-Year Plan.

## 4.3 Three & Five Year Plans

### 4.3.1 TANESCO Three-Year Programme

Specific Loss Remediation	Units	2011	2012	2013	Total
<b>11kV Overhead Networks</b>					
<b>Convert to 33kV:</b>					
11kV Line Length	km	200	250	315	765
Development Cost	US\$M	10.8	13.6	17.1	41.5
Loss Saving - Energy	MWh	19,320	24,150	30,429	73,900
Loss Saving - Energy	%Points/Input	0.36	0.46	0.57	1.39
Loss Saving - Capitalised Value	US\$M	47.1	58.8	74.1	180.0
<b>Install Fixed 11kV Capacitors:</b>					
No 11kV Feeders		66	66	66	198
Total Capacitors	MVAR	60	60	60	180
Development Cost	US\$M	0.9	0.9	0.9	2.8
Loss Saving - Energy	MWh	2,977	2,977	2,977	8,930
Loss Saving - Energy	%Points/Input	0.06	0.06	0.06	0.17
Loss Saving - Capitalised Value	US\$M	7.3	7.3	7.3	21.8
<b>LV Networks</b>					
<b>New MV/LV Substations:</b>					
Development Cost	US\$M	3.4	4.0	4.0	11.4
Loss Saving - Energy	MWh	6,453	7,503	7,503	21,460
Loss Saving - Energy	%Points/Input	0.12	0.14	0.14	0.40
Loss Saving - Capitalised Value	US\$M	15.5	18.1	18.1	51.7
<b>Reconductor LV Feeders:</b>					
LV Feeder Length	km	500	700	780	1,320
Development Cost	US\$M	5.0	7.0	7.8	13.2
Loss Saving - Energy	MWh	14,621	20,470	22,809	38,600
Loss Saving - Energy	%Points/Input	0.28	0.39	0.43	0.73
Loss Saving - Capitalised Value	US\$M	0.0	0.0	0.0	94.7
<b>Totals</b>					
Development Cost	US\$M	20.2	25.5	29.8	68.9
Loss Saving - Energy	MWh	43,371	55,100	63,719	142,890
Loss Saving - Energy	%Points/Input	0.8	1.0	1.2	2.7
Loss Saving - Capitalised Value	US\$M	69.9	84.2	99.5	348.2

**Figure 4.1 TANESCO Technical Loss Reduction Program – 2011 to 2013**

The programme indicated can be expected to yield 2.7 percentage points technical loss reduction over this period. This would reduce the present TANESCO T&D system loss rate from 24.4% of inputs to 21.7% and contribute to the targeted reduction of 6 percentage points overall in this period.

Within the time period 2013 to 2015 it can be expected that the presently planned major transmission system developments, particularly the new 400kV lines, will have significant impact on the present very high transmission system loss rate. It is difficult to assess the timing and impact of these projects at this stage. But a 1 – 2 percentage point reduction should be achievable.

Within the 2013 to 2015 time period the improved distribution planning and development processes should be well in place and delivering results. It is assumed that initial impact will just keep up with the impact of load growth in the early years to 2013. Between 2013 and 2015 the policy should begin to have noticeable impact. Beyond 2015 these improved processes should be the primary method for loss management and reduction. The need for special remedial projects should phase out around 2015.

**In 2013 performance should be reviewed to assess the impact of the special loss reduction projects and ongoing network development. It is expected that the special projects will still be needed up to 2015.** The projection therefore is to continue the program based on 2013 levels through the following two years until 2015. This should yield an additional loss reduction of 2.4 percentage points up to 2015 at a development cost of US\$60 million.

### 4.3.2 ZECO Three-Year Programme

Specific Loss Remediation	Units	2011	2012	2013	Total
<b>11kV Overhead Networks</b>					
<b>Convert to 33kV:</b>					
11kV Line Length	km		27	27	54
Development Cost	US\$M		1.40	1.40	2.80
Loss Saving - Energy	MWh		922	922	1,844
Loss Saving - Energy	%Points/Input		0.40	0.40	0.80
Loss Saving - Capitalised Value	US\$M		2.25	2.25	4.50
<b>Install Fixed 11kV Capacitors:</b>					
No 11kV Feeders		1	2	1	4
Total Capacitors	MVAR	1.3	2.5	1.3	5.1
Development Cost	US\$M	0.02	0.04	0.02	0.08
Loss Saving - Energy	MWh	120	230	120	469
Loss Saving - Energy	%Points/Input	0.05	0.10	0.05	0.20
Loss Saving - Capitalised Value	US\$M	0.29	0.56	0.29	1.14
<b>LV Networks</b>					
<b>New MV/LV Substations:</b>					
Development Cost	US\$M	0.24	0.73	0.73	1.45
Loss Saving - Energy	MWh	261	783	783	1,566
Loss Saving - Energy	%Points/Input	0.11	0.34	0.34	0.68
Loss Saving - Capitalised Value	US\$M	0.63	1.89	1.89	3.77
<b>Reconductor LV Feeders:</b>					
LV Feeder Length	km	14	35	35	84
Development Cost	US\$M	0.14	0.35	0.35	0.84
Loss Saving - Energy	MWh	298	745	745	1,788
Loss Saving - Energy	%Points/Input	0.13	0.32	0.32	0.78
Loss Saving - Capitalised Value	US\$M	0.75	1.87	1.87	4.48
<b>Totals</b>					
Development Cost	US\$M	0.4	2.5	2.5	5.2
Loss Saving - Energy	MWh	679	2,680	2,570	5,667
Loss Saving - Energy	%Points/Input	0.3	1.2	1.1	2.5
Loss Saving - Capitalised Value	US\$M	1.7	6.6	6.3	13.9

**Figure 4.2 ZECO Technical Loss Reduction Program – 2011 to 2013**

The indicated programme can be expected to yield 2.5 percentage points technical loss reduction over this period. This would reduce the present ZECO system loss rate from 25.5% of inputs to 23% and contribute to the targeted reduction of 6 percentage points overall in this period. The capitalised value of loss savings at \$13.9m compares to development costs of about \$5.2m.

The projection is to continue the program based on 2013 levels through the following two year until 2015. This should yield an additional loss reduction of 2.2 percentage points up to 2015 at a development cost of US\$5 million.

## 5 Commercial Loss Reduction

### 5.1 Commercial Loss Reduction Strategies

#### 5.1.1 Surveys

The customer surveys carried out as part of the project provided some evidence of illegal connections to the system and interference with meters.

In the TANESCO service area a total of 522 customers' premises were visited and considerable information gathered.

The summary results for the survey are shown in Figure 5.1 below.

Stopped meters	17*
Illegal connection	2*
Illegal re-connection (three-phase)	1*
Account number not available on site	4
Fake seal used	1*
Unregistered customer	1*
Incorrect meter record	2
Probable or definite interference	18*
Zero consumption	31
Zero consumption and suspicious	3*
Inadequate sealing	27

*\*Indicates evidence of interference and/or commercial losses*

**Figure 5.1 Summary Survey Results TANESCO**

Based on this survey, it was found that approximately 8% of installations visited were likely to be causing a commercial loss. This included installations actively interfered with as well as stopped meters, of which there was a significant number, As the Consultant's surveyors did not have access to consumption information and did not dismantle any of the installations, it is most likely that the actual figure is higher, probably about 12%.

A similar survey was carried out in ZECO. A total of 160 customer premises were visited, including 41 on Pemba and figure 5.2 below shows a summary of the survey results for Zanzibar (Unguja and Pemba).

Zero Consumption	14
Zero Consumption suspicious	3*
Stopped Meters	8*
Damaged Meters	6*
Completely unsealed	26
Suspected Interference	3*
Questionable meter readings	5

*\*Indicates evidence of possible interference and/or commercial losses*

**Figure 5.2 Summary Survey Results ZECO**

In general approximately 12% of installations gave cause for concern, not counting those solely with missing seals. This is higher than the detection rate for the mainland although given the higher level of losses, this figure was to be expected. However as is the case on the mainland, the number found in the surveys is most likely an underestimate. The lack of proper meter seals was a particularly noticeable issue, particularly on Pemba, and may be indicative of further interference.

**5.1.2 Revenue Protection Strategy**

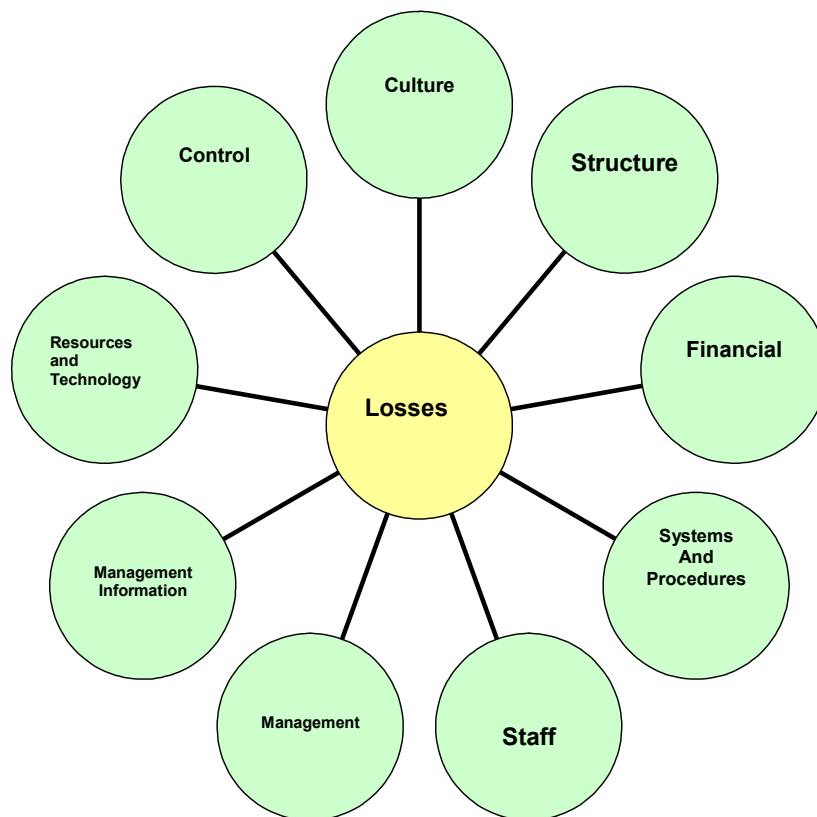

**Figure 5.3 Elements of Revenue Protection Strategy**

There is no single solution to the problem of commercial losses. Within TANESCO and ZECO, the problems are varied and require an integrated approach. In the course of the study, AZOROM has identified nine elements which must be addressed as part of an integrated strategy in order to combat commercial losses. These elements are: Culture & Environment, Organisation Structure, Financial implications, Systems and Procedures in use, Staff, Management, Management Information, Resources & Technology and Control. Figure 5.3 shows the interaction between these elements. It is critical that the recommendations in this report are seen as an integrated strategy to combat losses

The main elements of the strategy include:

### **Culture and Environment**

- Implement over a period a staff awareness programme combined with sanctions to change the culture of corruption and collusion by a few.
- Implement a public awareness campaign to advise customers of the implications of electricity theft and to encourage 'whistle blowers' to provide information
- Commence moves to have the legal powers strengthened to help secure convictions for electricity theft

### **Financial**

- Increase provision for incentive payments for both staff and 'whistle blowers'
- Develop regime of undertaking cost-benefit analysis of initiatives
- Ensure that payment channels are adequate to encourage convenient purchase of credit or payment of bills

### **Systems and Procedures**

- Produce a comprehensive policy document on revenue protection to be communicated to all
- Develop a system of focused visits to premises where theft may be suspected
- Utilise meter readers to a much greater degree to report suspect installations
- Take urgent action to find the source(s) of fake prepayment tokens

### **Staff**

- Ensure sanctions against staff for theft or collusion are enforced
- Provide a programme of training in revenue protection
- Review policy of where temporary employees may be located

### **Management Information**

- Develop a suite of management information to assist the RP activity
- Introduce appropriate targets at all levels to incentivise the activity with KPIs for Regional Managers and HQ managers.
- Monitor customer complaints closely to improve performance

## Controls

- Review controls currently in place and introduce appropriate additional ones
- Document controls to ensure consistency
- Internal Audit should have the appropriate level of involvement in ensuring that controls are being adhered to

## Technology, Equipment and Resources

- Provide proper resourcing for revenue protection units, including personnel and transport
- Consider the use of portable meter-testing equipment for on-site testing
- Pilot an extension of the split-meter concept (currently under consideration for AMR customers) to specific non-AMR customers.

## Organisation, Structure and Responsibilities

- Appoint a 'champion' at senior level in both organisations with specific responsibility for revenue protection
- Change reporting relationship of regional Revenue Protection Engineers and change the title to open the position to non-engineers
- Set up a revenue protection unit in TANESCO HO with responsibility for both large and other users
- Set up a revenue protection unit in ZECO, reporting to Senior Manager, Commercial, separate from the Technical inspections function.
- Consider a greater role for Zonal managers in the longer term

## Management

- Proper planning of revenue protection activity needs to be undertaken with short-term, medium-term and longer-term plans prepared at the appropriate level
- Management development should be provided for Revenue Protection Managers and for Zonal Managers in the future.

## 5.2 Three & Five Year Plans

### 5.2.1 Three-year Plan 2011 - 2013

The following is a summarised list of the main recommendations dealt with under section 5.2 of the main report.

	<b>Initiative</b>	<b>Start</b>	<b>Complete</b>
1.	Put new RP organisation in place and nominate senior manager responsible	2011	2011
2.	Recruitment of staff for RP units	2011	2011
3.	Ensure inclusion of comprehensive incentive mechanism for RP staff in new policy	2011	2013

4.	Provide resources for RP units <ul style="list-style-type: none"> <li>• Vehicles</li> <li>• Field and support staff</li> <li>• Portable test equipment</li> <li>• IT support</li> </ul>	2011	2011
5.	Develop and deliver training programme for RP staff	2011	2012
6.	Staff awareness programme	2011	2013
7.	Develop management information requirements <ul style="list-style-type: none"> <li>• Billing system</li> <li>• Prepayment system</li> <li>• Management reports</li> </ul>	2011	2011
8.	Make IT system changes	2011	2013
9.	Develop and implement customer awareness campaign <ul style="list-style-type: none"> <li>• Media campaign</li> <li>• Information leaflets</li> <li>• Confidential telephone line</li> </ul>	2011	2013
10.	Implement programme to clear backlog of stopped meters & maintain on an ongoing basis	2011	2013
11.	Implement programme to follow up zero consumption and zero-purchase	2011	2012
12.	Use information from billing and prepayment systems to identify suspicious consumption	2011	2013
13.	Develop list of high-probability categories and investigate	2011	2013
14.	Develop list of previous offenders and investigate	2011	2013
15.	Review meter-reader contracts to <ul style="list-style-type: none"> <li>• Ensure integrity</li> <li>• Receive reports on suspicious cases</li> <li>• Provide incentive mechanism</li> </ul>	2011	2012
16.	Programme of database cleaning	2011	2013
17.	Develop and document controls on meter seal management and implement meter sealing programme	2011	2013
18.	Implement changes necessary to reduce new connection lead times including procurement.	2011	2012
19.	Lobby for legislative change – prepare case for Minister, seek support of EWURA	2011	2013
20.	Continue roll-out of AMR	2011	2013
21.	Install AMR split meters and review	2011	2012
22.	Pilot non-AMR split meters and review performance with manufacturers	2011	2013
23.	Complete installation of anti-tamper meters and review strategy	2011	2012
24.	Investigate source(s) of fake prepayment meter tokens in TANESCO	2011	2012

**Figure 5.4 Three-year Plan**

### 5.2.2 Five-Year Plan 2014 - 2015

	<b>Initiative</b>
	Review progress of 2011 - 2013 plans including benefit – cost outcome
	Set loss reduction target for 2015
	Undertake customer attitude survey
	Devise and implement strategy for 2014 – 2015 <ul style="list-style-type: none"> <li>• Continue with successful initiatives</li> <li>• Modify or replace unsuccessful initiatives</li> <li>• Greater focus needed to meet more stretching targets</li> </ul>
	Review RP organisation and resourcing
	Implement meter test and replacement policy
	Continue roll-out of AMR split meters to the next level
	Implement non-AMR split meters in specific locations assuming successful pilot
	Implement programme of installation of anti-tamper meters assuming successful pilots and manufacturer modifications as identified
	Devise and implement programme to complete GPS referencing of customers
	Ensure RP requirements are included in GIS system development

**Table 5.5 Five-year Plan**

It is worth pointing out that the timetable for the programmes proposed, particularly the first phase, is extremely challenging. The timeline has been determined by the terms of reference for the project. In order to have a realistic chance of success, it will be essential that once approved, implementation must commence immediately.

### 5.3 Economic Analysis of the Programme

An analysis of the costs and benefits of the programme for the years 2011 to 2013 for both TANESCO and ZECO was carried out. The costs of personnel, transport, tools, training, publicity, IT changes etc were included in the costs and a range of scenarios for successful detections and revenue recovered was run. The result was overwhelmingly positive with break-even within the first year and a Net Present Value of 38 billion Tsh at a discount rate of 20%.

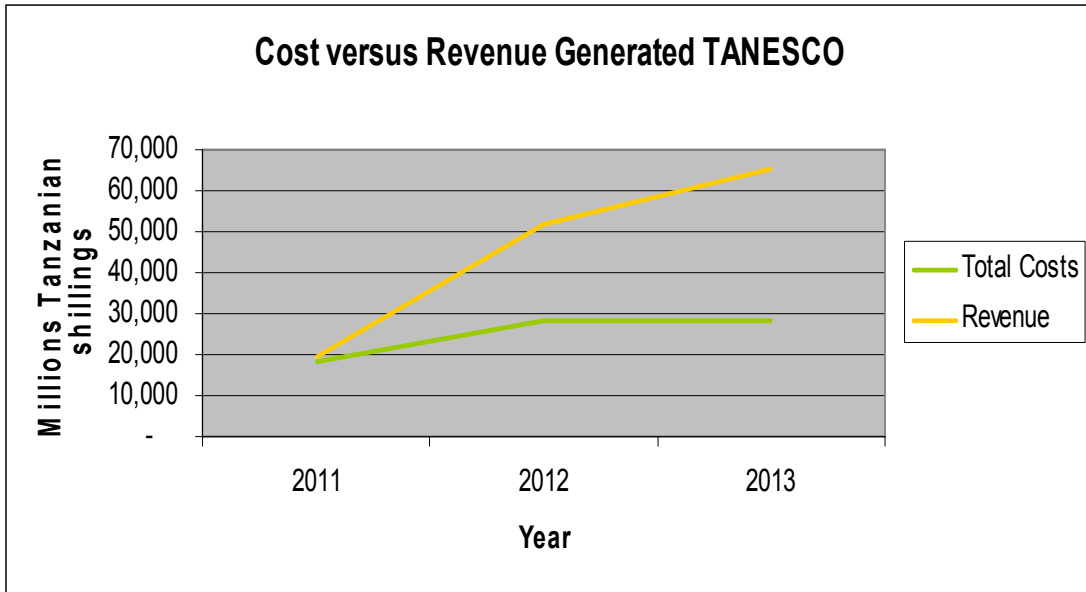

**Figure 5.6 Cost-benefit TANESCO**

In the case of ZECO, the economies of scale that are available to TANESCO do not apply to Zanzibar and the economic evaluation does not yield such spectacular results. Nevertheless the break-even point still occurs in year 1 and the Net Present Value is 1.2 billion Tsh. The case is represented graphically in Figure 5.7.

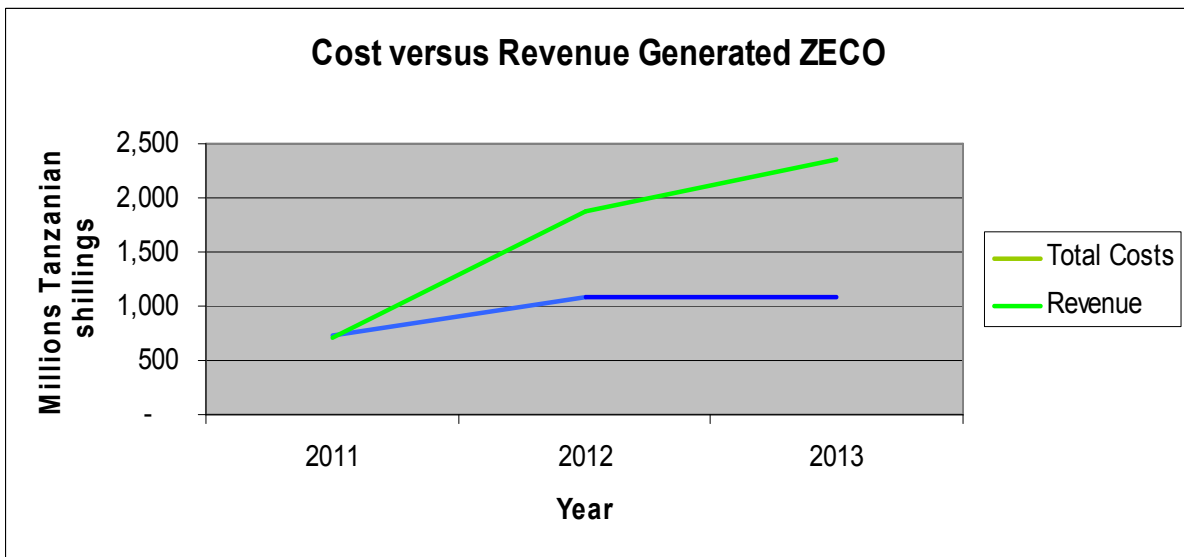

**Figure 5.7 Cost-benefit ZECO**

In order to achieve these levels of loss reduction it will be necessary to provide resources as indicated above. The exact level will depend on the success rate in detecting irregularities and recovering revenue.

## 6 Conclusions and Recommendations

### 6.1 Conclusions in Summary

- Huge challenges face both utilities, but there is very good payoff (financially and in regulatory and customer goodwill) in adopting loss reduction programmes
- Many good initiatives have already been taken in TANESCO and ZECO which can be built on and can inspire confidence in management and donors when approving investment plans
- In order to achieve the loss reductions it will be vital to front load the programmes with commercial loss reduction as technical loss reductions will take time to be realised.
- TANESCO need to reduce Commercial losses by about one third by end of 2013 so that, combined with some 2.7% reduction in Technical losses, the target of reduction of T&D losses by about 6% can be achieved
- ZECO need to reduce Commercial losses by about one third by end 2013 so that, combined with 2.5% reduction in Technical losses, the target of reducing all system losses to below 20% can be achieved
- Investments of \$68.9m in TANESCO and of \$5.2m in ZECO will be required to deliver the Technical loss reductions by 2013, with payback periods of two to four years.
- Increases in operating expenditure of approximately \$7m per annum in TANESCO will be required to deliver the commercial losses target, including extra staff, transport, equipment and training
- Similarly an increase in expenditure of \$500,000 per annum in ZECO will be required.
- Delivery of the reduced technical losses will be the equivalent of providing extra generating capacity of 62MW in TANESCO and of 2.3 MW in ZECO by 2015
- Sustainability of the loss reduction programmes will be critical and strong championing of Revenue Protection and proper Network Planning by top management in both utilities for at least 5 years will be required

### 6.2 Main Recommendations

#### Corporate:

- MD TANESCO and GM ZECO should propose to their Boards that they adopt targets for loss reductions to 18% and 20% respectively by 2013, with a reduction of up to 40% in commercial losses
- Top management in both companies should seek Board Approval for expenditure of the necessary resources to achieve these targets, as tabled in this study
- The Corporate plan for both companies should include a full study/audit of loss levels and costs on their systems every 2 to 3 years

#### Organisation:

- Champions of loss reduction to be appointed immediately in each company by top management
- Management in TANESCO should make the organisational changes recommended for immediate implementation in Revenue Protection in HQ and in regions; and in Distribution network planning in HQ and in regions
- GM ZECO should ensure immediate implementation of proposed organisational changes relating to Revenue Protection and Network Design, and should seek Technical Assistance to support both functions for 6 to 12 months
- In 2012, TANESCO should carry out a review of the potential role of Zonal Managers in enhancing Revenue Protection /Loss Reduction
- In 2012, ZECO should review loss levels in Pemba and arrange necessary remedial action

### **Legal/HR:**

- Support from the Minister for Energy and from EWURA should be sought for legal changes and greater penalties to enable TANESCO prosecute *vishoka* and those abstracting energy illegally more effectively
- Staff and their representatives in both companies to be advised that instant dismissal will apply to staff who have colluded with *vishoka* or consumers in electricity theft

### **Technical Losses Reduction:**

- Perform annual review of loss performance across T&D networks
- Strengthen network Planning and Design functions in HQ and in regions, with explicit acceptance of loss optimisation in policies and standards, and prepare a review of System Development management across Distribution and Transmission
- Carry out detailed planning for the 4 programmes of loss reduction proposed above in both utilities (MV capacitors; 11kV to 33kV conversion; new 11kV/LV subs, and LV re-conductoring)
- Acquire Network Analysis software and populate databases established by AZOROM with peak load readings and energy meter records, annually
- Arrange a study of GIS application to MV networks
- Size new conductors based on economic load levels, not thermal ratings. These are about 25% of thermal rating.
- Capitalise transformer losses on purchase and include in purchase appraisal.

### **Commercial Losses Reduction:**

- Communicate all 9 elements of integrated Loss Reduction strategy to management and front-line Revenue Protection staff and gain acceptance of the target reductions
- Solve the procurement issues which cause shortages in meters, and in materials required for new connections
- Ensure the required extra inspection staff, fully equipped with transport and intelligence/ information are in place as soon as possible, and arrange appropriate training and additional meter test equipment

- Establish commercial loss reduction as a Key Performance Indicator and have the new Management Information specialist publish monthly packs showing regional performance on a league table basis
- Reaffirm sealing policy for both companies, and change Billing and Prepayment systems to record seals, with Pemba as a pilot region in ZECO
- Trial split meters in non-AMR areas (as well as for AMR customers)

**Inter-Company:**

- Appoint representatives from both TANESCO and ZECO to:
  - agree on energy flows across both interconnectors in 2009, so that more accurate loss calculations for both systems can be made
  - monitor loss levels on the interconnectors with Unguja and Pemba

# Appendices

### Appendix A: TANESCO Cost Structure (Approximate)

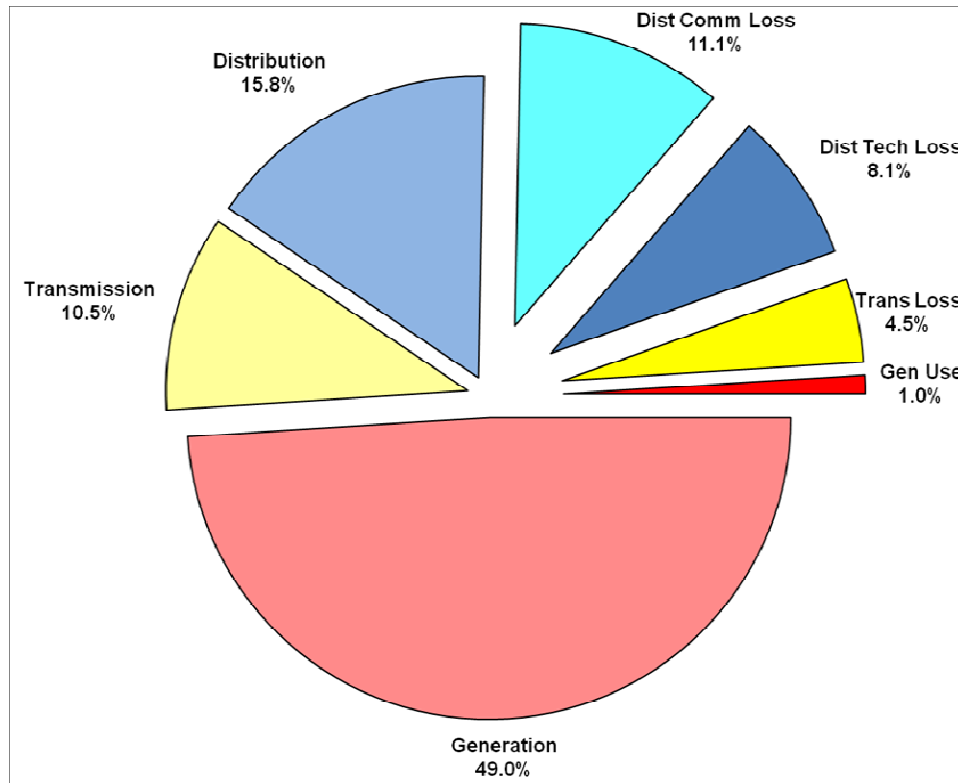

### Appendix B: TANESCO System Energy Flow 2010

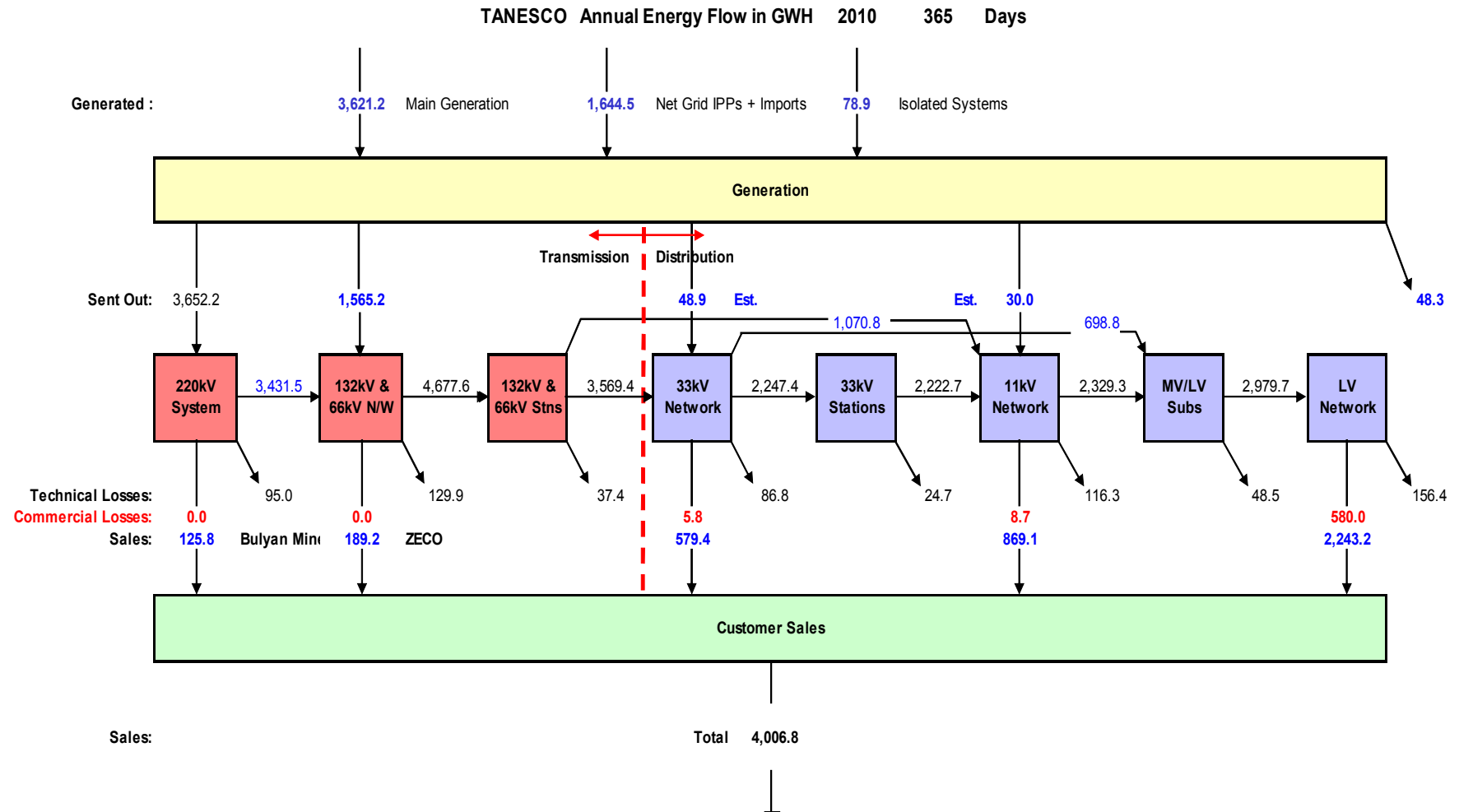

### Appendix C: ZECO System Energy Flow 2009

